

# OUTDOOR PUMP WITH GAUGE



This pump is a great addition to bike rooms, parks, trails, or other public heavy-use settings. Designed to withstand extreme weather conditions, it ensures durability so that all the components are ready for action when needed by the users. Options to mount directly to the surface on its own or integrated into our Deluxe Public work stand.

## Product Specifications

- Outdoor-rated stainless steel construction, completely sealed
- Proprietary long-life piston seal and solid pump rod
- Steel-braided air hose core prevents cutting
- Includes all-metal High Performance Pump Head with Presta and Schrader Valves
- Includes hanging clip for hose
- Features integrated pressure gauge

# Outdoor Pump with Gauge

## Recommended Setbacks for floor mouted option



Installation hardware included



Stainless steel construction



2 year warranty

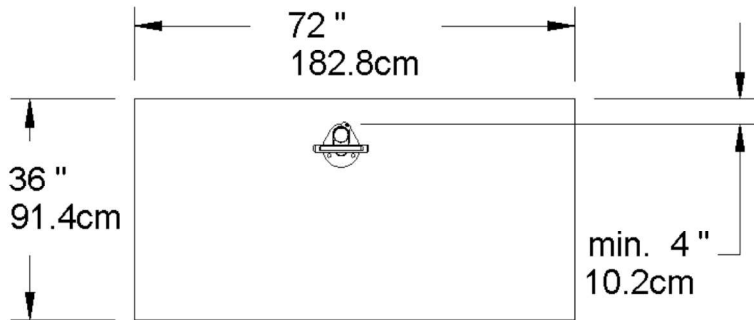

The minimum space requirements for High Security Bike Pumps are meant to allow a cyclist and their bike access to the pump.

## Outdoor Pump Line Drawing Dimensions



**Proprietary High performance pump head**

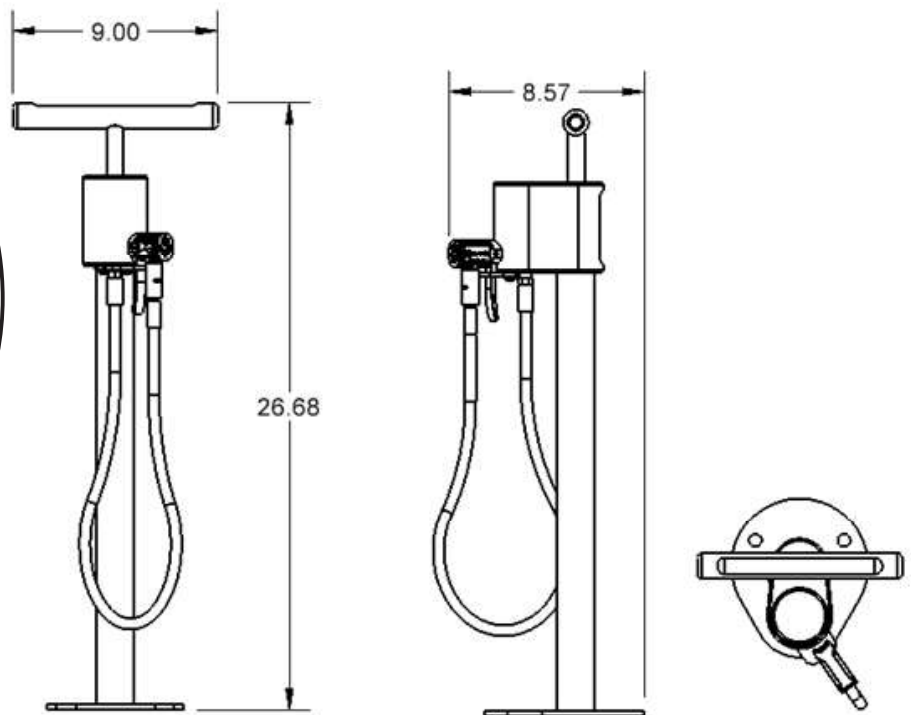

Dimensions					
Model #	Type of Mount	Weight	Length	Width	Height
26246	Floor	20 lbs.	8"	8"	30"
26242	Repair Stand	20 lbs.	8"	8"	30"

Design files and additional product resources available online at [sarisinfrastucture.com](http://sarisinfrastucture.com)